

ГИГИЕНИЧЕСКИЕ ПНЕВМОНАСОСЫ VA-2H40 3A



Архангельск (8182)63-90-72
Астана (7172)727-132
Астрахань (8512)99-46-04
Барнаул (3852)73-04-60
Белгород (4722)40-23-64
Брянск (4832)59-03-52
Владивосток (423)249-28-31
Волгоград (844)278-03-48
Вологда (8172)26-41-59
Воронеж (473)204-51-73
Екатеринбург (343)384-55-89

Иваново (4932)77-34-06
Ижевск (3412)26-03-58
Иркутск (395)279-98-46
Казань (843)206-01-48
Калининград (4012)72-03-81
Калуга (4842)92-23-67
Кемерово (3842)65-04-62
Киров (8332)68-02-04
Краснодар (861)203-40-90
Красноярск (391)204-63-61
Курск (4712)77-13-04
Липецк (4742)52-20-81

Магнитогорск (3519)55-03-13
Москва (495)268-04-70
Мурманск (8152)59-64-93
Набережные Челны (8552)20-53-41
Нижний Новгород (831)429-08-12
Новокузнецк (3843)20-46-81
Новосибирск (383)227-86-73
Омск (3812)21-46-40
Орел (4862)44-53-42
Оренбург (3532)37-68-04
Пенза (8412)22-31-16

Пермь (342)205-81-47
Ростов-на-Дону (863)308-18-15
Рязань (4912)46-61-64
Самара (846)206-03-16
Санкт-Петербург (812)309-46-40
Саратов (845)249-38-78
Севастополь (8692)22-31-93
Симферополь (3652)67-13-56
Смоленск (4812)29-41-54
Сочи (862)225-72-31
Ставрополь (8652)20-65-13

Сургут (3462)77-98-35
Тверь (4822)63-31-35
Томск (3822)98-41-53
Тула (4872)74-02-29
Тюмень (3452)66-21-18
Ульяновск (8422)24-23-59
Уфа (347)229-48-12
Хабаровск (4212)92-98-04
Челябинск (351)202-03-61
Череповец (8202)49-02-64
Ярославль (4852)69-52-93

Россия (495)268-04-70 Киргизия (996)312-96-26-47 Казахстан (772)734-952-31

Единый адрес для всех регионов: www.verderair.nt-rt.ru || vru@nt-rt.ru

VERDERAIR

VA-2H40 3A







The VA-2H40 3A is a hygienic designed air operated double diaphragm pump. With the wide range of materials for valve seats, ball valves and diaphragms, this pump is the ideal problem solver for numerous hygienic applications. The VA-2H series is used where a high degree of food safety is required. The VA-2H is a reliable, easy to operate pump.

Your benefits

- Most hygienic design for food applications
- Efficient engineered design which reduces the risk of contamination (low amount of products which come into contact with the medium)
- A high quality product with best price-performance ratio
- Can run against closed discharge valve without the need of overpressure safety equipment
- Dry self-priming

Technical Data			
Weight (kg)	Ball version	40,4	
Suction lift (mWc)	dry	3	
	wet	9,1	
Temperature limits internals (°C)	EPDM	-40	135
	Neoprene	-18	82
	PTFE overmold diaphragms	4	82
Max. particle size (mm)	Ball versions	12,7	
Max. viscosity (mPas)		15000	
Fluid displacement/cycle (litres)	Ball versions	2,46	
Certifications	All models	-	CE / FDA / 3A
	Internals diaphragms	EO, TO with TF valves	EN1935/2004
		EO with TF valves	USP class VI

Code VA-2H40 No.1 No.2 No.3 No.4 No.5 No.6 No.7 No.8		
No. 1 Fluid Section Material X = 316 Stainless Steel, Ra : 0,8µm No. 2 Air Section Material S = 316 Stainless Steel No. 3 Check Valve seat material SE = SS seat with EPDM o-rings ST = SS seat with EP-TF o-rings 	No. 4 Check ball valves material EP = EPDM NW = Neoprene weighted  TF = PTFE No. 5 Diaphragm material  EO = EPDM overmolded  TO = PTFE/EPDM overmolded No. 6 Connections D4 = DIN 11851, DN40, male T4 = Tri-Clamp (ASME BPE), 1 1/2"	No. 7 Pump Style 3A = ball valve execution, 3A (leak sensors included) No. 8 Wetted material certifications 21 = EN 10204 type 2.1 31 = EN 10204 type 3.1 

NOTE not all combinations are available

 EN 1935/2004

EXAMPLE PUMP TYPE
VA-2H40XS ST TF TO D4 3A 31

VERDERAIR

VA-2H40 3A



Dimensions (mm)

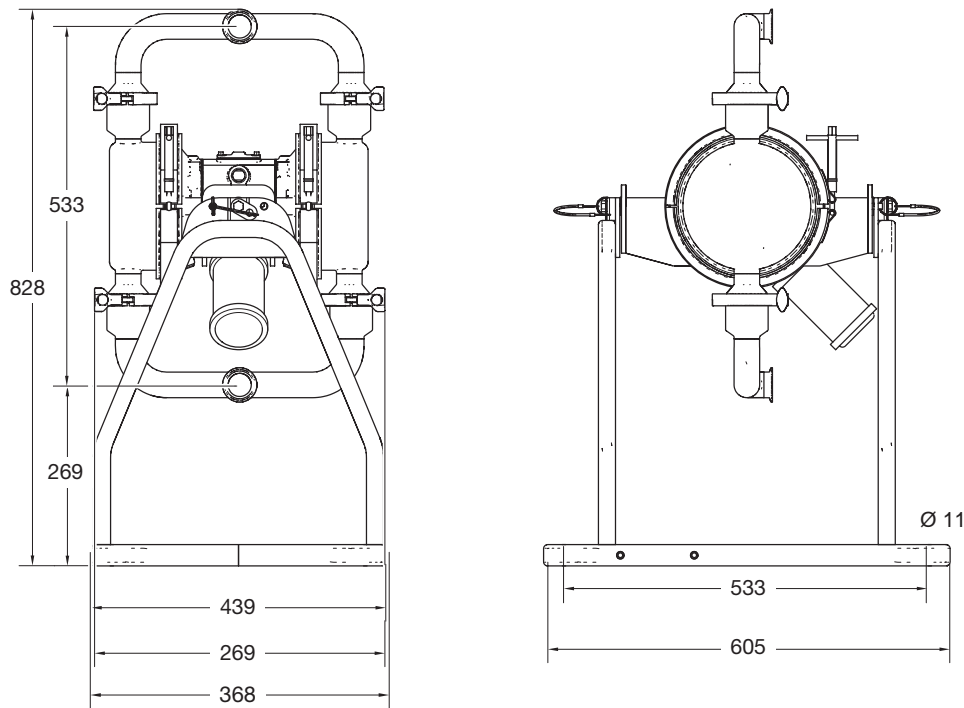

Flow rate / air consumption

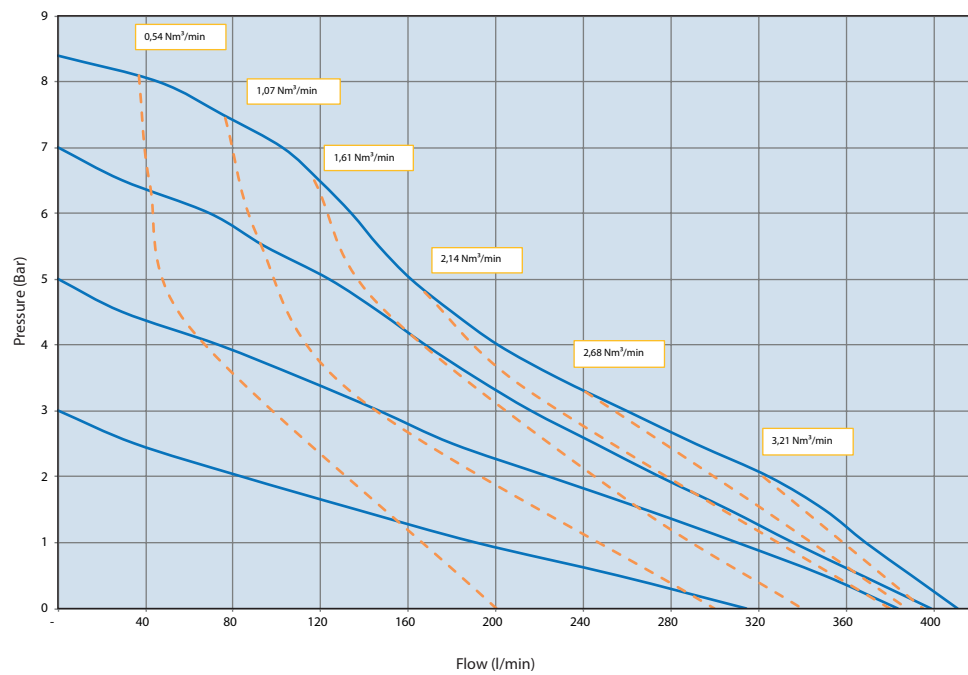

VERDERAIR

VA-2H40 3A



Viscosity correction curve

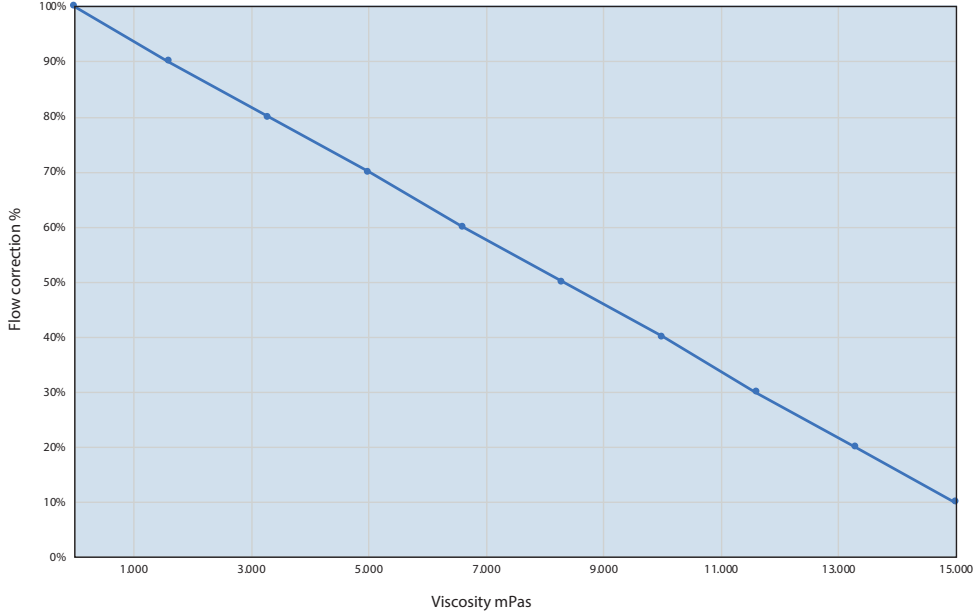



Архангельск (8182)63-90-72	Иваново (4932)77-34-06	Магнитогорск (3519)55-03-13	Пермь (342)205-81-47	Сургут (3462)77-98-35
Астана (7172)727-132	Ижевск (3412)26-03-58	Москва (495)268-04-70	Ростов-на-Дону (863)308-18-15	Тверь (4822)63-31-35
Астрахань (8512)99-46-04	Иркутск (395)279-98-46	Мурманск (8152)59-64-93	Рязань (4912)46-61-64	Томск (3822)98-41-53
Барнаул (3852)73-04-60	Казань (843)206-01-48	Набережные Челны (8552)20-53-41	Самара (846)206-03-16	Тула (4872)74-02-29
Белгород (4722)40-23-64	Калининград (4012)72-03-81	Нижний Новгород (831)429-08-12	Санкт-Петербург (812)309-46-40	Тюмень (3452)66-21-18
Брянск (4832)59-03-52	Калуга (4842)92-23-67	Новокузнецк (3843)20-46-81	Саратов (845)249-38-78	Ульяновск (8422)24-23-59
Владивосток (423)249-28-31	Кемерово (3842)65-04-62	Новосибирск (383)227-86-73	Севастополь (8692)22-31-93	Уфа (347)229-48-12
Волгоград (844)278-03-48	Киров (8332)68-02-04	Омск (3812)21-46-40	Симферополь (3652)67-13-56	Хабаровск (4212)92-98-04
Вологда (8172)26-41-59	Краснодар (861)203-40-90	Орел (4862)44-53-42	Смоленск (4812)29-41-54	Челябинск (351)202-03-61
Воронеж (473)204-51-73	Красноярск (391)204-63-61	Оренбург (3532)37-68-04	Сочи (862)225-72-31	Череповец (8202)49-02-64
Екатеринбург (343)384-55-89	Курск (4712)77-13-04	Пенза (8412)22-31-16	Ставрополь (8652)20-65-13	Ярославль (4852)69-52-93
	Липецк (4742)52-20-81			

Россия (495)268-04-70 Киргизия (996)312-96-26-47 Казахстан (772)734-952-31

Единый адрес для всех регионов: www.verderair.nt-rt.ru || vru@nt-rt.ru