

ДИАФРАГМЕННЫЕ ЭЛЕКТРОНАСОСЫ VA-E25



Архангельск (8182)63-90-72
Астана (7172)727-132
Астрахань (8512)99-46-04
Барнаул (3852)73-04-60
Белгород (4722)40-23-64
Брянск (4832)59-03-52
Владивосток (423)249-28-31
Волгоград (844)278-03-48
Вологда (8172)26-41-59
Воронеж (473)204-51-73
Екатеринбург (343)384-55-89

Иваново (4932)77-34-06
Ижевск (3412)26-03-58
Иркутск (395)279-98-46
Казань (843)206-01-48
Калининград (4012)72-03-81
Калуга (4842)92-23-67
Кемерово (3842)65-04-62
Киров (8332)68-02-04
Краснодар (861)203-40-90
Красноярск (391)204-63-61
Курск (4712)77-13-04
Липецк (4742)52-20-81

Магнитогорск (3519)55-03-13
Москва (495)268-04-70
Мурманск (8152)59-64-93
Набережные Челны (8552)20-53-41
Нижний Новгород (831)429-08-12
Новокузнецк (3843)20-46-81
Новосибирск (383)227-86-73
Омск (3812)21-46-40
Краснодар (861)203-40-90
Орел (4862)44-53-42
Оренбург (3532)37-68-04
Пенза (8412)22-31-16

Пермь (342)205-81-47
Ростов-на-Дону (863)308-18-15
Рязань (4912)46-61-64
Самара (846)206-03-16
Санкт-Петербург (812)309-46-40
Саратов (845)249-38-78
Севастополь (8692)22-31-93
Симферополь (3652)67-13-56
Смоленск (4812)29-41-54
Сочи (862)225-72-31
Ставрополь (8652)20-65-13

Сургут (3462)77-98-35
Тверь (4822)63-31-35
Томск (3822)98-41-53
Тула (4872)74-02-29
Тюмень (3452)66-21-18
Ульяновск (8422)24-23-59
Уфа (347)229-48-12
Хабаровск (4212)92-98-04
Челябинск (351)202-03-61
Череповец (8202)49-02-64
Ярославль (4852)69-52-93

Россия (495)268-04-70 Киргизия (996)312-96-26-47 Казахстан (772)734-952-31

Единый адрес для всех регионов: www.verderair.nt-rt.ru || vru@nt-rt.ru

Verderair

VA-E25

Description

The VA-E25 is an electrical driven double diaphragm pump. With the wide range of different available materials for pump body, valve seats, valve balls and diaphragms, this pump is the ideal problem solver in a wide range of applications across many industries. The VA-E25 can run in “low pulsation mode” to reduce the generated pulsations in the flow or in “transfer mode” to generate a higher flow rate.







Your benefits

- Energy efficient
- Smoother flow when operating in “low pulsation mode”
- Low noise level
- Can stall against close discharge
- Can run dry without damage
- Dry self priming

Technical data	Drive option	Fluid & air section			
	IG	AA	33,6		
		PA	32,4		
		PS	46,7		
		SA	40,6		
		SS	54,9		
		Weight [kg]	AC, BC	Extra weight on the drive option IG above	+ 23
AX, BX	Extra weight on the drive option IG above		+48		
A2, B2	Extra weight on the drive option AC/BC above		+ 13		
Max. Suction lift (mwc)		Dry	4,9		
		Wet	8,8		
Temperature (°C)	A,S	Internals			
		AC,BN	-12	82	
		VT	-40	135*	
		GE	-40	66	
		NO,NE, NW	-18	82	
		PP	0	66	
		TO	4	82	
		TF	4	104	
		SP	-40	82	
		HY	-29	66	
		P	All except TF,TO	0	66
			TF, TO	4	66

Drive option			
Electric Motor	AC, BC, A2, B2	Power (kW)	1,5
		Voltage (V)	3 x 230/460 - 50
	AX, BX	Power (kW)	1,5
		Voltage (V)	3x 240/415 - 50
Max. Particle size (mm)		3,2	
Air connection		3/8" NPT(f)	
Air consumption (Nm³/h)		< 0,006	
Max. recommended viscosity (mPas)		10.000	

Code VA-E25 No.1 No.2 No.3 No.4.No.5.No.6.No.7.		
<p>No.1 Fluid section</p> <p> A = Aluminium  S = Stainless Steel P = Polypropylene</p> <p>No.2 Center section</p> <p>A = Aluminium S = Stainless Steel</p> <p>No.3 Check valve seats</p> <p>AC = Acetal AL = Aluminium BN = Buna-N GE = Geolast HY = Hytrel (TPE) PP = Polypropylene SP = Santoprene SS = Stainless Steel 316 VT = Viton (FKM)</p>	<p>No. 4 Check valve balls</p> <p>AC = Acetal BN = Buna-N GE = Geolast</p> <p>HY = Hytrel (TPE) NE = Neoprene NW = Neoprene Weighted SP = Santoprene SS = Stainless Steel 316 TF = PTFE VT = Viton (FKM)</p> <p>No. 5 Diaphragms</p> <p>BN = Buna-N GE = Geolast HY = Hytrel (TPE) NO = Neoprene overmolded SP = Santoprene</p>	<p>TF = PTFE/EPDM 2 piece TO = PTFE/EPDM overmolded VT = Viton (FKM)</p> <p>No. 6 Connections</p> <p>TB = Threaded BSP(f) TN = Threaded NPT(f) FC = Center Flange DIN/ANSI FE = End Flange DIN/ANSI</p> <p>No. 7 Drive options</p> <p>AC = 159 RPM, Gearbox with AC drive BC = 80 RPM, Gearbox with AC drive  AX = 159 RPM, Gearbox with Atex drive  BX = 80 RPM, Gearbox with Atex drive  IG = IEC 90 gearbox (18,08 ratio) A2 = AC + Compressor 240V B2 = BC + Compressor 240V</p>

EXAMPLE PUMP TYPE

VA-E25 AA HY AC HY TB AC

NOTE not all combinations are available

 II 2 GD ck Ex d IIB T3 Gb

 II 2 GD ck IIB T3 Gb

Verderair

VA-E25

Performance curve

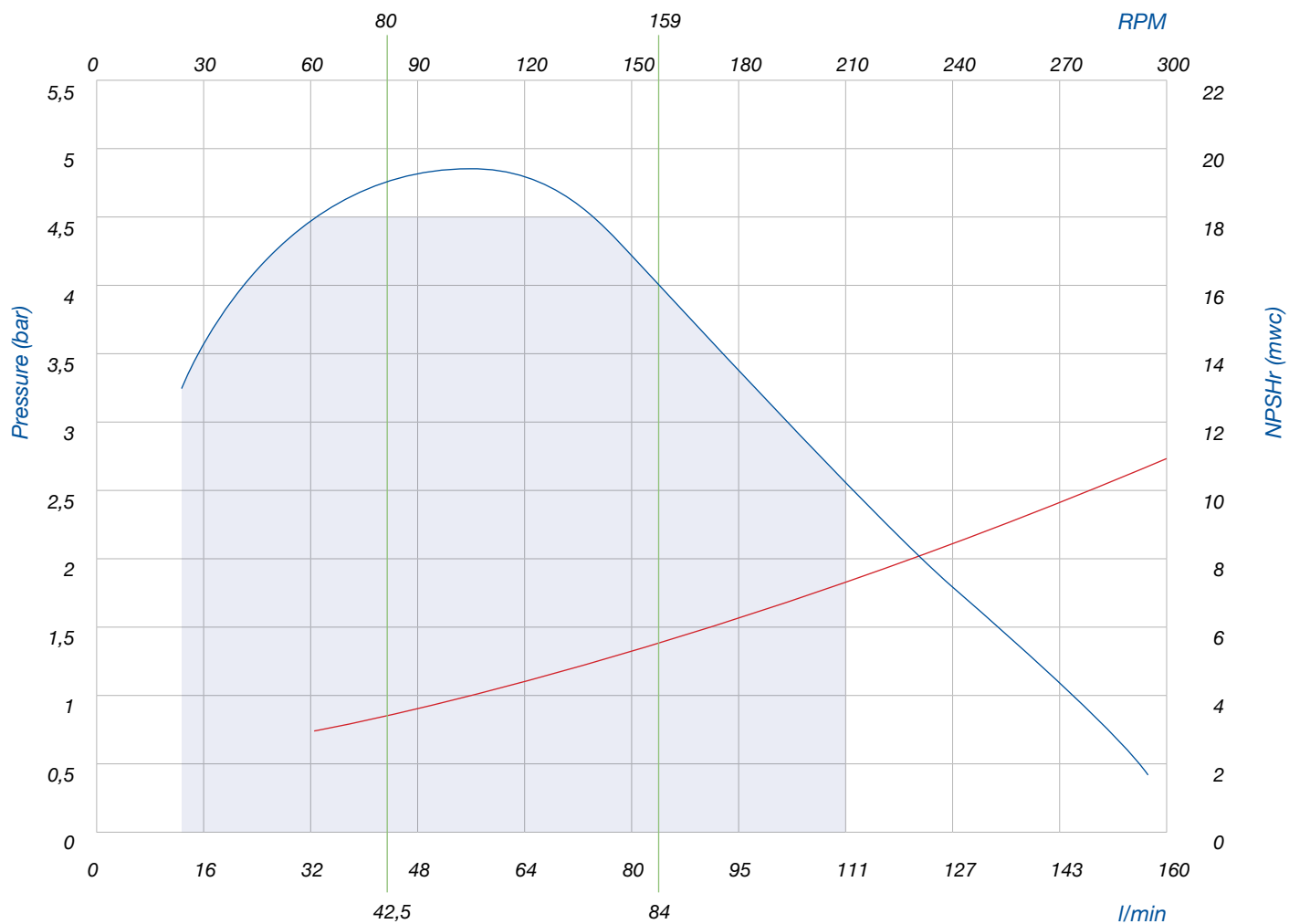

Dimensions (mm)

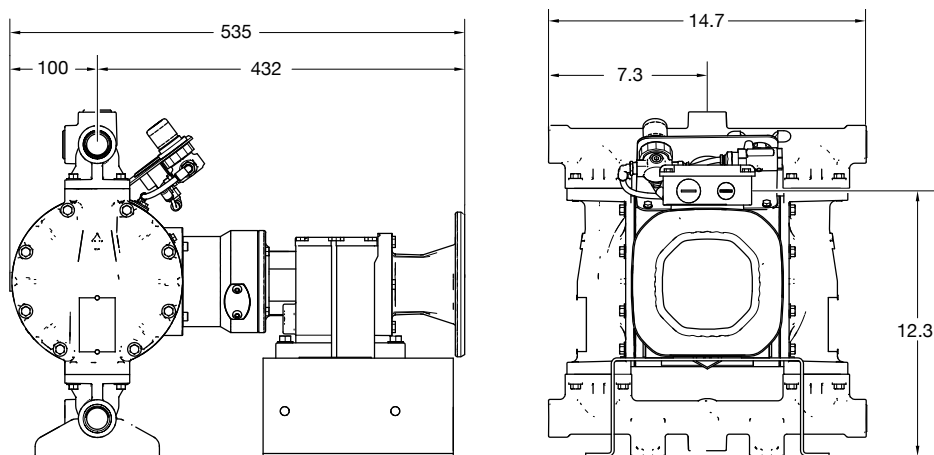

(Aluminium version with IC drive)



Архангельск (8182)63-90-72
Астана (7172)727-132
Астрахань (8512)99-46-04
Барнаул (3852)73-04-60
Белгород (4722)40-23-64
Брянск (4832)59-03-52
Владивосток (423)249-28-31
Волгоград (844)278-03-48
Вологда (8172)26-41-59
Воронеж (473)204-51-73
Екатеринбург (343)384-55-89

Иваново (4932)77-34-06
Ижевск (3412)26-03-58
Иркутск (395)279-98-46
Казань (843)206-01-48
Калининград (4012)72-03-81
Калуга (4842)92-23-67
Кемерово (3842)65-04-62
Киров (8332)68-02-04
Краснодар (861)203-40-90
Красноярск (391)204-63-61
Курск (4712)77-13-04
Липецк (4742)52-20-81

Магнитогорск (3519)55-03-13
Москва (495)268-04-70
Мурманск (8152)59-64-93
Набережные Челны (8552)20-53-41
Нижний Новгород (831)429-08-12
Новокузнецк (3843)20-46-81
Новосибирск (383)227-86-73
Омск (3812)21-46-40
Краснодар (861)203-40-90
Орел (4862)44-53-42
Оренбург (3532)37-68-04
Пенза (8412)22-31-16

Пермь (342)205-81-47
Ростов-на-Дону (863)308-18-15
Рязань (4912)46-61-64
Самара (846)206-03-16
Санкт-Петербург (812)309-46-40
Саратов (845)249-38-78
Севастополь (8692)22-31-93
Симферополь (3652)67-13-56
Смоленск (4812)29-41-54
Сочи (862)225-72-31
Ставрополь (8652)20-65-13

Сургут (3462)77-98-35
Тверь (4822)63-31-35
Томск (3822)98-41-53
Тула (4872)74-02-29
Тюмень (3452)66-21-18
Ульяновск (8422)24-23-59
Уфа (347)229-48-12
Хабаровск (4212)92-98-04
Челябинск (351)202-03-61
Череповец (8202)49-02-64
Ярославль (4852)69-52-93

Россия (495)268-04-70 Киргизия (996)312-96-26-47 Казахстан (772)734-952-31

Единый адрес для всех регионов: www.verderair.nt-rt.ru || vru@nt-rt.ru